

Dimensioni e allacciamenti – Dimension and connections

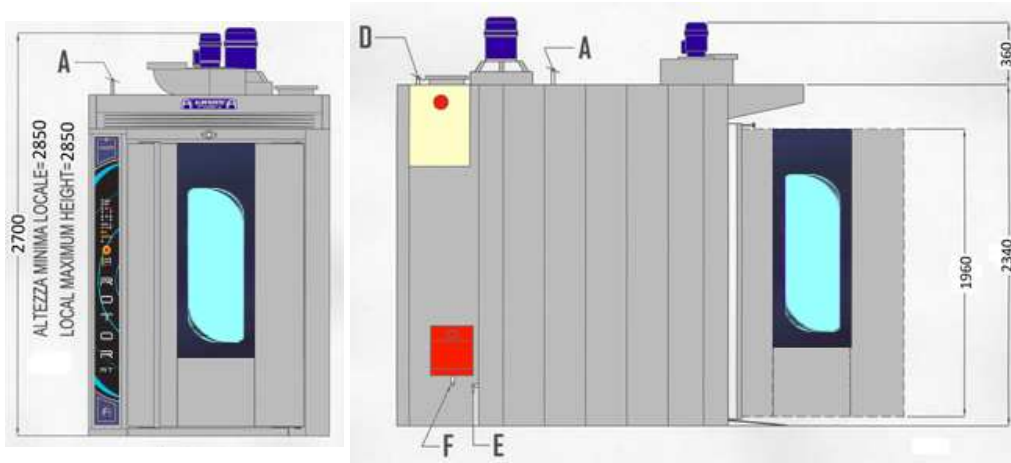

Descrizione sigle – Description abbreviations

A	ARRIVO ACQUA ½" (+2400) WATER INLET
B	SCARICO VAPORI Ø 200 (+2500) EXHAUST STEAM
C	SCARICO FUMI Ø 200 (+2400) EXHAUST SMOKES
D	ARRIVO E.ELETTRICA KW3 (+2400) ELECTRICITY INLET
E	SCARICO ACQUA ½" (+200) WATER DISCHARGE
F	ARRIVO COMBUSTIBILE (+300) FUEL INLET

Caratteristiche tecniche – Technical specification

Potenzialità Termica Nominale Nominal Terminal Power	KCAL/H 80000 (KW 93)
---	-----------------------------

Dimensioni e allacciamenti – Dimension and connections

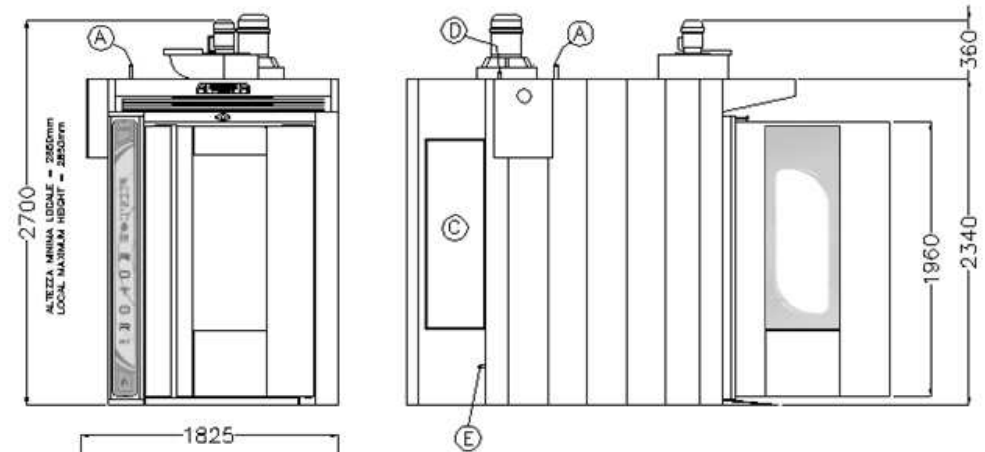

Descrizione sigle – Description abbreviations

A	ARRIVO ACQUA Ø½" H=2400mm WATER INLET Ø½" H=2400mm
B	SCARICO VAPORI Ø 200 H=2500mm EXHAUST STEAM Ø 200 H=2500mm
C	GRUPPO RESISTENZE ELETTRICHE GROUP ELECTRIC HEATERS
D	ARRIVO E.ELETTRICA 380V-3 FASI + NEUTRO H=2400mm ELECTRICITY INLET 380V-3 PHASES + NEUTRAL H=2400mm
E	SCARICO ACQUA Ø½" H=300mm WATER DISCHARGE Ø H=300mm

Caratteristiche tecniche – Technical specification

Potenza Elettrica Electric Power	66 kw
-------------------------------------	--------------