

Z M < 0 3 > M + 1 0

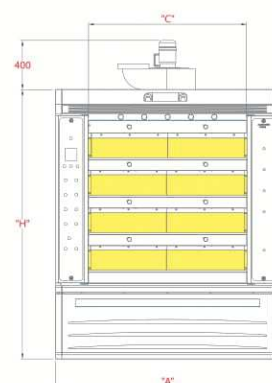
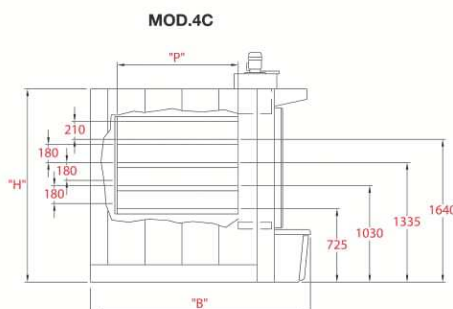
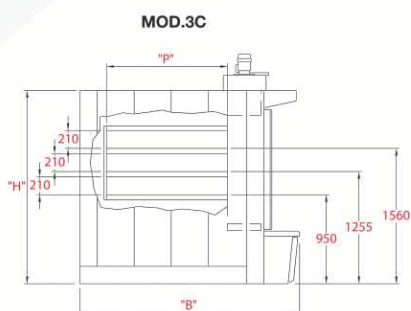

Mod. ST120	Modello Model Modelo	Superficie di cottura mq	N° Camere Chambres Càmaras	N° Sportelli Doors Porte Puertas	Dimensioni camere Chambers size Dimensions chambres Dimensiones câmaras		Dimensioni esterne Overall dimensions Dimensions extérieures Dimensiones externas		Massa Weight Poids Masa Kg	Potenzialità Termica Thermic Power Puissance Thermique Potencia Tèrmica Kcal/h	Bruciatore a gasolio Consigliato Recommen ded oil burner RIELLO	Bruciatore a gas consigliato Recommen ded gas burner AVANZINI
					Largh x Lung Width x Depth Larg x Prof Anch x Prof C x D = mm	Altezza Height Hauteur Altura cm	Largh x Lung Width x Depth Larg x Prof Anch x Prof A x B = mm	Altezza Height Hauteur Altura mm				
3C	ST120/3/1L	5.00	3	6° x 620	1240 x 1370	21/21/21	1930 x 2680	2300	5900	45.000 (KW 52)	RG2F	ANGAS 15
	ST120/3/2L	6.70	3	6° x 620	1240 x 1790	21/21/21	1930 x 3100	2300	6400	60.300 (KW 69)	RG2F	ANGAS 15
	ST120/3/3L	7.40	3	6° x 620	1240 x 2000	21/21/21	1930 x 3310	2300	6800	66.600 (KW 77)	RG2F	ANGAS 15
	ST120/3/4L	8.20	3	6° x 620	1240 x 2210	21/21/21	1930 x 3520	2300	7400	73.800 (KW 85)	RG2F	ANGAS 15
	ST120/3/5L	9.00	3	6° x 620	1240 x 2420	21/21/21	1939 x 3730	2300	7700	81.000 (KW94)	RG2F	ANGAS 15
4C	ST120/4/1L	6.80	4	8° x 620	1240 x 1370	18/18/18/21	1930 x 2680	2300	6300	54.400 (KW 62)	RG2F	ANGAS 15
	ST120/4/2L	8.90	4	8° x 620	1240 x 1790	18/18/18/21	1930 x 3100	2300	6800	71.200 (KW 82)	RG2F	ANGAS 15
	ST120/4/3L	10.00	4	8° x 620	1240 x 2000	18/18/18/21	1930 x 3310	2300	7300	80.000 (KW 93)	RG2F	ANGAS 15
	ST120/4/4L	11.00	4	8° x 620	1240 x 2210	18/18/18/21	1930 x 3520	2300	7500	88.000 (KW102)	RG2F	ANGAS 15
	ST120/4/5L	12.00	4	8° x 620	1240 x 2420	18/18/18/21	1939 x 3730	2300	8000	96.000 (KW 111)	RG2F	ANGAS 15