

Z M < 0 > M - 1 0

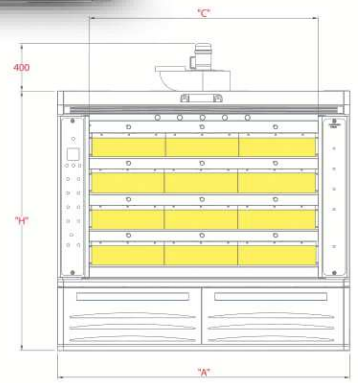
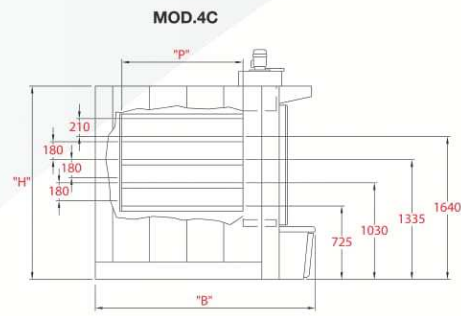
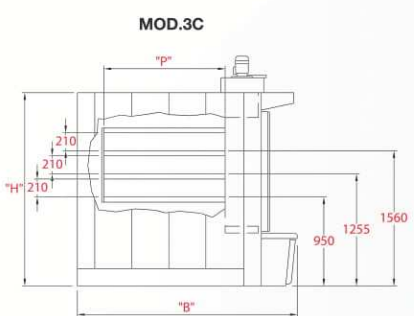

Mod. ST180	Modello Model Modèle Modelo	Superficie di cottura mq	N° Camere Chambres Càmaras	N° Sportelli Doors Porte Puertas	Dimensioni camere Chambers size Dimensions chambres Dimensiones càmaras		Dimensioni esterne Overall dimensions Dimensions extérieures Dimensiones externas		Massa Weight Poids Masa Kg	Potenzialità Termica Thermic Power Puissance Thermique Potencia Tèrmica Kcal/h	Bruciatore a gasolio Consigliato Recommen ded oil burner RIELLO	Bruciatore a gas consigliato Recommen ded gas burner AVANZINI
					LarghxLung WidthxDepth LargxProf AnchxProf C x D = mm	Altezza Height Hauteur Altura cm	LarghxLung WidthxDepth LargxProf AnchxProf A x B = mm	Altezza Height Hauteur Altura mm				
3C	ST180/3/1L	7.60	3	9° x 620	1860 x 1370	21/21/21	2550 x 2680	2300	7200	60.800 (KW 70)	RG2F	ANGAS 15
	ST180/3/2L	10.00	3	9° x 620	1860 x 1790	21/21/21	2550 x 3100	2300	7700	80.000 (KW 93)	RG2F	ANGAS 15
	ST180/3/3L	11.10	3	9° x 620	1860 x 2000	21/21/21	2550 x 3310	2300	8000	88.800 (KW 103)	RG3F	ANGAS 15
	ST180/3/4L	12.30	3	9° x 620	1860 x 2210	21/21/21	2550 x 3520	2300	9000	98.400 (KW 114)	RG3F	ANGAS 15
	ST180/3/5L	13.50	3	9° x 620	1860 x 2420	21/21/21	2550 x 3730	2300	9500	108.000 (KW 125)	RG3F	ANGAS 15
	ST180/3/6L	14.60	3	9° x 620	1860 x 2630	21/21/21	2550 x 3940	2300	9800	116.800 (KW 136)	RG3F	ANGAS 15
4C	ST180/4/1L	10.20	4	12° x 620	1860 x 1370	18/18/18/21	2550 x 2680	2300	7800	81.600 (KW 94)	RG3F	ANGAS 15
	ST180/4/2L	13.30	4	12° x 620	1860 x 1790	18/18/18/21	2550 x 3100	2300	8000	104.400 (KW 121)	RG3F	ANGAS 15
	ST180/4/3L	14.80	4	12° x 620	1860 x 2000	18/18/18/21	2550 x 3310	2300	9000	118.400 (KW 137)	RG3F	ANGAS 15
	ST180/4/4L	16.40	4	12° x 620	1860 x 2210	18/18/18/21	2550 x 3520	2300	9500	131.200 (KW 152)	RG3F	ANGAS 15
	ST180/4/5L	18.00	4	12° x 620	1860 x 2420	18/18/18/21	2550 x 3730	2300	10200	144.000 (KW 167)	RG3F	ANGAS 15
	ST180/4/6L	19.50	4	12° x 620	1860 x 2630	18/18/18/21	2550 x 3940	2300	10900	156.000 (KW 181)	RG4F	ANGAS 20